

X20035  
TRIAC DRIVERS

# DMFC12

415v, 230v, 110v, 24v, 15v  
Dual Mode Firing Circuit

## CONTACT US:

☎ 0044 (0) 1704-516 501  
✉ enquiries@united-automation.com  
🌐 www.united-automation.com



## KEY FEATURES:

- ✓ Supports phase-angle and burst-fire control for optimal power regulation.
- ✓ Soft-start (0-30s).
- ✓ Current limit (using external CT/Hall-effect device or shunt with amplification)
- ✓ Wide Signal Compatibility: Accepts 0-5V/0-10V, 0-20mA/4-20mA, or potentiometer input signals.
- ✓ DIN Rail Mount: Standard DIN rail mounting for easy installation and integration.
- ✓ Frequency tracking (4Hz – 400Hz)
- ✓ Flexible Power Supply: Operates on 24VDC or 18-24VAC supply, ensuring compatibility with different systems.
- ✓ High-resolution version available
- ✓ Durable and Compact.

## APPLICATIONS:

The DMFC12 is ideal for a variety of industrial applications, including heater control, motor speed regulation, lighting control, and more.

Its dual-mode firing capability and robust design make it a preferred choice for engineers seeking reliable and efficient power management solutions.

The **DMFC12 Dual Mode Firing Circuit** is a versatile and reliable power control solution designed for industrial applications. This advanced module supports both phase-angle and burst-fire modes, making it ideal for precise control of power in various resistive and inductive loads. With its compact design and standard DIN rail mounting, the DMFC12 is easy to integrate into existing systems. It offers a wide range of input signal options and includes essential features like soft-start, current limit functionality, and phase-loss detection.

The DMFC12 is the ultimate solution for industrial power control, offering precision, flexibility, and reliability in a compact, easy-to-install package.

## TECHNICAL SPECIFICATIONS

|  |   |
|--|---|
| <b>PH1 &amp; PH2 Voltage Phase Ref. [10 &amp; 11] (VAC RMS <math>\pm 10\%</math>; Var./Fixed freq. 4 to 400Hz)</b> | 415V, 230V, 110V, 24V, 15V AC (Other voltages available upon request) |
| <b>Input Power Supply (nominal) [1 &amp; 2]</b>  | 18 to 24 VAC or 24VDC @ 200mA   |
| <b>Signal span minimum</b>   | 0-4VDC  |
| <b>Signal span maximum</b>   | 0-25VDC   |
| <b>Signal zero offset</b>  | +60% and -40% of Span   |
| <b>Manual potentiometer</b>  | 1K $\Omega$ , 5K $\Omega$ or 10K $\Omega$                             |
| <b>Signal Input resistance</b>   | 5K $\Omega$ ("V" Signal), 250 $\Omega$ ("mA" Signal) $\pm 10\%$       |
| <b>Limit feedback input</b>  | 3-25VDC   |
| <b>Soft start</b>  | 0-30 seconds (adjustable)   |
| <b>Thyristor (SCR) line voltage</b>  | See Order Details   |
| <b>Trigger pulse height</b>  | 8VDC open circuit   |
| <b>Trigger isolation voltage</b>   | 2500VAC (RMS)   |
| <b>Trigger pulse rating</b>  | 250mA in to 10 $\Omega$   |
| <b>Storage temperature</b>   | 0°C to +65°C  |
| <b>Max unit operating temperature</b>  | 70°C  |
| <b>Dimensions (Inc. DIN Enclosure) (D x H x W) (mm)</b>  | 122 x 70 x 56   |



BMF House - Wight Moss Way,  
Southport Business Park  
Southport PR8 4HQ  
ENGLAND

united automation unitedautomationltd UA\_Limited



# DMFC12

415v, 230v, 110v, 24v, 15v | Dual Mode Firing Circuit

## INSTALLATION

### Warning

1. Live terminals – isolate supply before commencing any installation work
2. Unit must be secured on DIN rail using the DIN-housing supplied.

For CT Information see Datasheets X10391 (32A) and X10424 (240A)

### Connections

This unit has simple 2.5mm clamp type terminal connectors for all input wiring requirements and 6.3mm AMP Tags for the Gate / Kathode (G/K) connections.

### Fastening

The unit is secured by DIN-rail mounting feet for quick installation/removal.

## TERMINAL CONNECTIONS

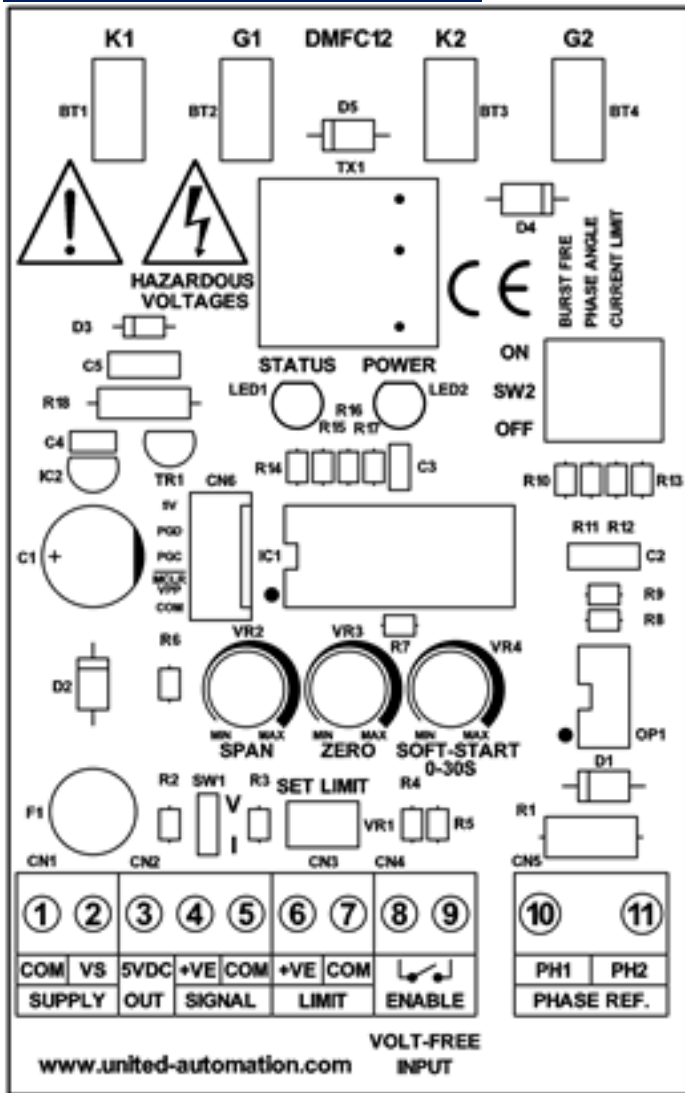

## POWER CONNECTIONS

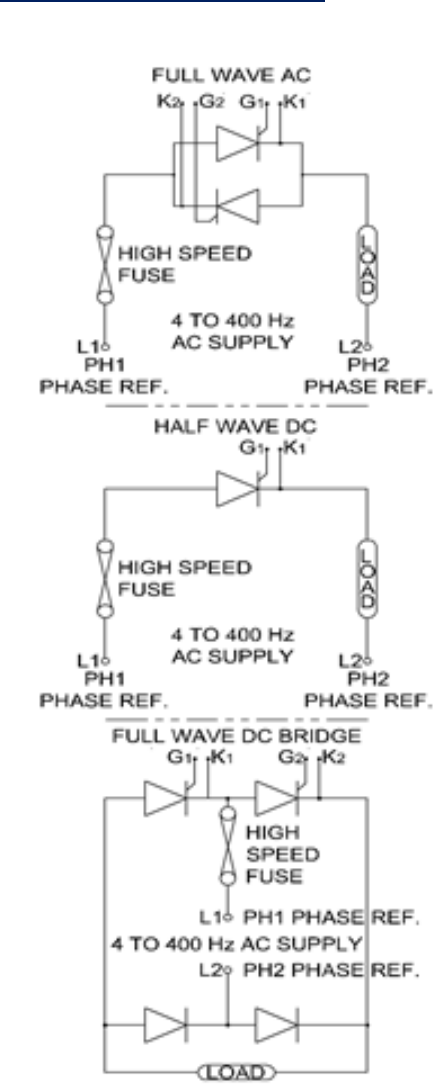

BMF House - Wight Moss Way,  
Southport Business Park  
Southport PR8 4HQ  
ENGLAND

unitedautomation | unitedautomationltd | UA\_Limited



# DMFC12

415v, 230v, 110v, 24v, 15v

Dual Mode Firing Circuit

## Additional Information

### Power Supply Terminals (1 & 2)

The DMFC12 accepts an 18-24VAC or 24VDC supply. This would be polarity sensitive when using a DC supply i.e., terminal 1: negative and terminal 2: positive.

### PH1 & PH2 Phase Reference Terminals (10 & 11)

See POWER CONNECTIONS (above) for typical wiring circuits. The connections made to the Phase ref. terminal are dependent on which circuit is being applied. F1A fusing should be fitted as appropriate (as shown opposite), e.g., for single phase (230V & 110V and lower) - fuse the LIVE; for two phase 400V - fuse both PHASES.

### Power Output Modes

#### These Modes must be set before power up.

The DMFC12 can be configured to operate in burst fire, phase angle or dual output modes. The burst fire time base is 1 second. The soft start feature only works in phase angle mode and can be set between 0 (disabled) and 30 seconds. In dual mode, the DMFC12 soft starts in phase angle mode then switches to burst fire mode. The output modes are selected via the 4-way switch SW2.

- **Burst Fire Only** – BROWN (No.1) switch set to 'ON', RED switch set to 'OFF'
- **Phase Angle Only** – RED (No.2) switch set to 'ON', BROWN switch set to 'OFF'
- **Dual Mode** – Both BROWN and RED switches set to 'ON'

### Input Signal Terminals (3, 4 & 5)

The DMFC12 supports input signals in the range of 0-30Vdc and 0-20mA. This includes industry standard signals of 0-5V, 0-10V and 4-20mA. Also, a 5Vdc output is provided to allow a potentiometer to be connected directly to the DMFC12. The 'SPAN' (VR2) and 'ZERO' (VR3) cermets provide the facility to scale the input signal [See Typical Control Options section with SPAN and ZERO settings]. Switch SW1 sets the source of the input signal to voltage (V) or current (I).

### Current Limit Terminals (6 & 7)

The DMFC12 includes a current limit selected by SW2 DIL switch with ORANGE (No.3) in the 'ON' position. This feature prevents the load current from exceeding a pre-defined value. The unit accepts a D.C. voltage feedback signal which can be scaled via the on-board 'SET LIMIT' multiturn pre-set (VR1). The feedback signal is continuously compared to a 2.5V internal reference: reducing the output voltage when the magnitude of the feedback signal rises above it.



BMF House - Wight Moss Way,  
Southport Business Park  
Southport PR8 4HQ  
ENGLAND

# DMFC12

415v, 230v, 110v, 24v, 15v | Dual Mode Firing Circuit

## Enable Input Terminal (8 & 9)

A 'volts free' enable input allows the DMFC12 to be controlled externally. If configured, a 'soft start' occurs each time the DMFC12 is enabled. Close contacts to enable.

## Soft Start Adjustment

The 'soft start' ramps up power to the signal setting over the same proportion of time period selected by 'SOFT START' cermet (VR4). e.g., If the soft start is set for 30 seconds and the signal input is 50%, then the output will ramp up to 50% in 15 seconds.

## Span and Zero Adjustment

The Span and Zero cermets (VR2 & VR3) allow the user to set the minimum and maximum output voltage in relation to the input signal range [see Typical Control Options].

## LED Indicators

The DMFC12 has two LED indicators. The green 'Power' LED2 is lit when power is supplied to the DMFC12. The red 'Status' LED1 represents the current output power, and its intensity will vary for phase angle mode and flash on a 1-second time-base for burst fire mode. The red 'Status' LED1 also flashes rapidly when the phase reference signal is not present.

## Variable or Fixed Line Frequency

The DMFC12 is capable of providing power control with line voltages of fixed or varying frequencies from 4Hz to 400Hz by continually measuring the duration of each AC half-cycle and adjusting the timing of the thyristor gate signals.

## TYPICAL CONTROL OPTIONS

Adjust SPAN and ZERO to set the Maximum and Minimum Output Respectively

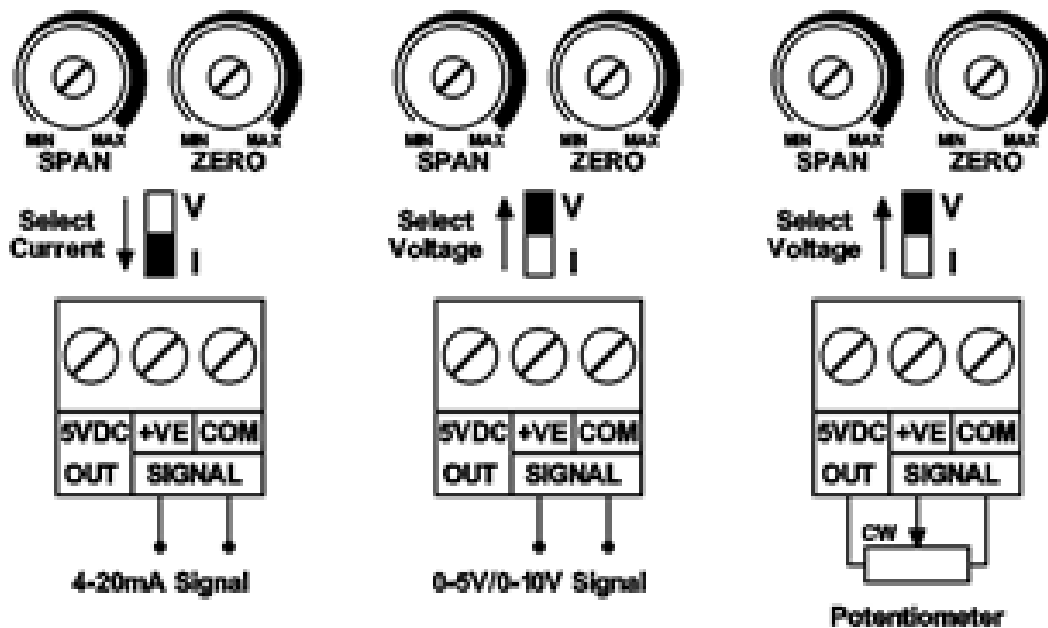

# DMFC12

415v, 230v, 110v, 24v, 15v

Dual Mode Firing Circuit

## RECOMMENDATIONS

### FUSING

See SRA Data sheet X10255 for further information. Other external supplies should be fused accordingly.

### DOCUMENTS

Other documents available on request, which may be appropriate for your application:

| Code   | Identity | Description   |
|--------|----------|---|
| X10213 | ITA      | Interaction: Uses for phase angle and for burst fire control  |
| X10255 | SRA      | Safety Requirements: Addressing the Low Voltage Directive (LVD) including, Thermal Data/Cooling, Live Parts Warning, Earthing Requirements and Fusing Recommendations |
| P01.1  | COS      | UAL Conditions of Sale  |

It is recommended that installation and maintenance of this equipment should be carried out by suitably qualified personnel with reference to the current edition of the I.E.E. wiring regulations (BS7671). The regulations contain important requirements regarding the safety of electrical equipment. For International Standards, refer to I.E.C./ Directive IEC 950.

### OPTIONAL EXTRAS

| Product Code | Product Description                      |
|--------------|--|
| A403001      | Manual (5K) Potentiometer Knob and Leads |

### PRODUCT CODE AND RELATED PRODUCT CODE

| Product Code  | Product Description                           |
|---------------|---|
| A34535        | DMFC12 - 415VAC - Dual Mode Firing Circuit    |
| A34534        | DMFC12 - 230VAC - Dual Mode Firing Circuit    |
| A34537        | DMFC12 - 110VAC - Dual Mode Firing Circuit    |
| A34540        | DMFC12 - 24VAC - Dual Mode Firing Circuit     |
| A34542        | DMFC12 - 15VAC - Dual Mode Firing Circuit     |
| Other Voltage | Contact us for a more specific voltage rating |



BMF House - Wight Moss Way,  
Southport Business Park  
Southport PR8 4HQ  
ENGLAND

united  
automation

[@](#) [f](#) [in](#) [d](#) [unitedautomationltd](#) [UA\\_Limited](#)

