

X20012

Soft Start Control



# Soft Start Controller with bypass contactor

110v, 230v – 3kW, 6kW

Enhance Load Protection and Efficiency

## CONTACT US:

☎ 0044 (0) 1704-516 501

✉ [enquiries@united-automation.com](mailto:enquiries@united-automation.com)

🌐 [www.united-automation.com](http://www.united-automation.com)



## KEY FEATURES:

- ✓ **Smooth Ramp-Up:** Adjustable 1-5 second ramp-on time to prevent sudden surges.
- ✓ **Pedestal Control:** Allows for 0-40% adjustment of the sine wave start.
- ✓ **High Switching Capacity:** Handles up to 6kW at 230V AC and 3kW at 110V AC.
- ✓ **Durable Construction:** IP65 rated enclosure to withstand harsh environments.
- ✓ **Easy Installation:** Equipped with 6.0mm<sup>2</sup> rising clamp terminals and a max cable entry diameter of 2.5mm<sup>2</sup>.

The Soft Start Controller with Contactor is designed to seamlessly manage the power-up process for both inductive and resistive loads, ensuring a smooth and controlled ramp-up that eliminates high inrush current. With a ramp-on time adjustable between 1 to 5 seconds and a pedestal value range of 0-40%, this device offers precise control to protect your equipment and prevent nuisance MCB trips.

Enhance the longevity and reliability of your electrical equipment with the Soft Start Controller with Contactor, designed for optimal performance and protection in demanding applications.

## APPLICATIONS:

The Soft Start Controller with Contactor is ideal for:

- **Transformers:** Smoothly starts transformers, preventing damage from inrush currents.
- **Motors:** Provides controlled power-up for motors, extending their lifespan.
- **Compressors:** Protects compressors from electrical surges during startup.
- **Resistive Loads:** Suitable for a variety of resistive loads, ensuring safe and efficient operation.

## TECHNICAL SPECIFICATIONS

<b>Supply Voltage</b>	230V AC ±10% @ 50/60Hz
<b>Switching Capacity</b>	6kW Max AT 230v AC 3Kw at 110v AC
<b>Ramp On-Time</b>	1-5 Seconds
<b>Pedestal Value</b>	0-40% (Conduction Angle)
<b>Current Consumption</b>	20mA
<b>Terminals</b>	6.0mm <sup>2</sup> Rising Clamp
<b>Operating Temperature</b>	-20 to 40°C
<b>Protection Rating</b>	IP65
<b>Gland Diameter</b>	Max. Cable Entry 2.5mm <sup>2</sup>
<b>Enclosure Dimensions (W x L x H)</b>	130 x 130 x 75mm
<b>Supply Voltage</b>	230V AC ±10% @ 50/60Hz
<b>Switching Capacity</b>	6kW Max AT 230v AC 3Kw at 110v AC



BMF House - Wight Moss Way,  
Southport Business Park  
Southport PR8 4HQ  
ENGLAND

united automation

[@](#) [f](#) [in](#) [d](#) [unitedautomationltd](#) [UA\\_Limited](#)



# Soft Start Controller with Bypass Contactor

110v, 230v – 3kW, 6kW Enhance Load Protection and Efficiency

## INSTALLATION

### **SAFETY FIRST!**

Please read these instructions thoroughly before installing and operating this product.

#### **Positioning and Mounting:**

- Position the Soft Start unit with the three fixed cable glands facing downward.
- Secure the unit using the four mounting holes accessible from the front.
- Use round cables to avoid water ingress.
- A mounting template is provided to locate the four mounting hole centres.

#### **Wiring**

**Important:** Installation and maintenance should be performed by qualified personnel, referencing the current edition of the I.E.E. wiring regulations (BS7671) for safety compliance (International Standards refer to I.E.C/directive IEC950).

**Warning:** Isolate the mains supply before beginning any work on the unit to avoid serious injury or fatality.

- **Cable Glands:** The unit has three cable glands:
  - Left gland: For the mains supply
  - Middle gland: For the load
  - Right gland: For the enable input

**Note:** Only one cable per gland should be used to maintain the unit's IP rating.

#### **Connections:**

- **Mains Supply:** Connect to the terminal block marked 'LINE'.
  - Live (L) to 'L' terminal
  - Neutral (N) to 'N' terminal
  - Earth (E) to 'E' terminal
- **Load:** Connect to the terminal block marked 'LOAD'.
  - Live (L) to 'L' terminal
  - Neutral (N) to 'N' terminal
  - Earth (E) to 'E' terminal
- **Enable Input:**
  - If an external enable signal is used, connect to the terminal block marked 'ENABLE'.
  - If no enable input is needed, insert a wire link into the Enable terminal.

**Important:** Ensure all earth wires are connected to maintain earth continuity. Double-check all wiring and ensure the cable glands are tightly secured.



BMF House - Wight Moss Way,  
Southport Business Park  
Southport PR8 4HQ  
ENGLAND



# Soft Start Controller with Bypass Contactor

110v, 230v – 3kW, 6kW Enhance Load Protection and Efficiency

## Commissioning

1. Set the Secs Cermet (VR2) to a value between 1 and 5 seconds.
2. If the Pedestal (VR1) is used, adjust it to a position between 0-40%. If not used, set it to 0%.
3. If an enable switch is needed, remove the link from the ENABLE terminal and attach the switch.
4. Replace the lid and switch on the mains supply to the unit.
5. The soft start should activate upon power-on if the link is fitted or when the ENABLE switch is engaged.

By following these instructions, you ensure the safe and efficient installation and operation of your Soft Start unit.

## Troubleshooting

**Warning:** Isolate the mains supply before commencing any work on the unit. Failure to do so could result in serious injury or fatality.

Problem	Solution
System Doesn't Start	<ol style="list-style-type: none"> <li>1. <b>Verify Mains Supply:</b> Ensure that the mains supply to the unit is switched on.</li> <li>2. <b>Check Enable Link:</b> Confirm that the Enable Link is properly fitted.</li> <li>3. <b>Inspect Wiring Connections:</b> <ul style="list-style-type: none"> <li>○ Check the LINE and LOAD wiring connections to both the unit and the load.</li> </ul> </li> <li>4. <b>Contact Supplier:</b> If the problem persists, contact your supplier for further assistance.</li> <li>5. Recommendations &amp; Safety Requirements</li> </ol>



BMF House - Wight Moss Way,  
Southport Business Park  
Southport PR8 4HQ  
ENGLAND



# Soft Start Controller with Bypass Contactor

110v, 230v – 3kW, 6kW Enhance Load Protection and Efficiency

## WIRING DIAGRAM

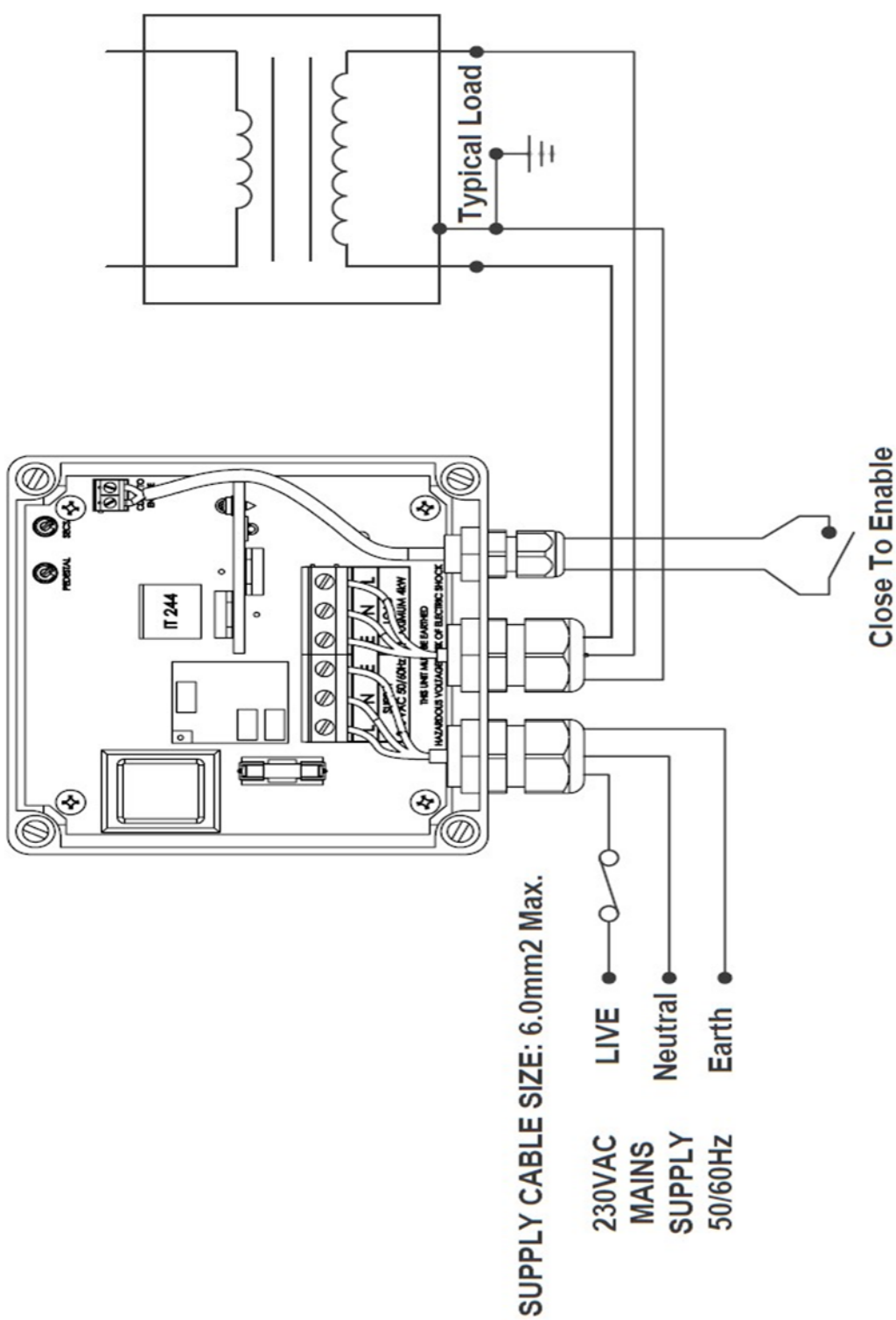

# Soft Start Controller with Bypass Contactor

110v, 230v – 3kW, 6kW Enhance Load Protection and Efficiency

## Mounting Template

**IMPORTANT!** The unit must be orientated when wall mounting with the cable glands facing down.

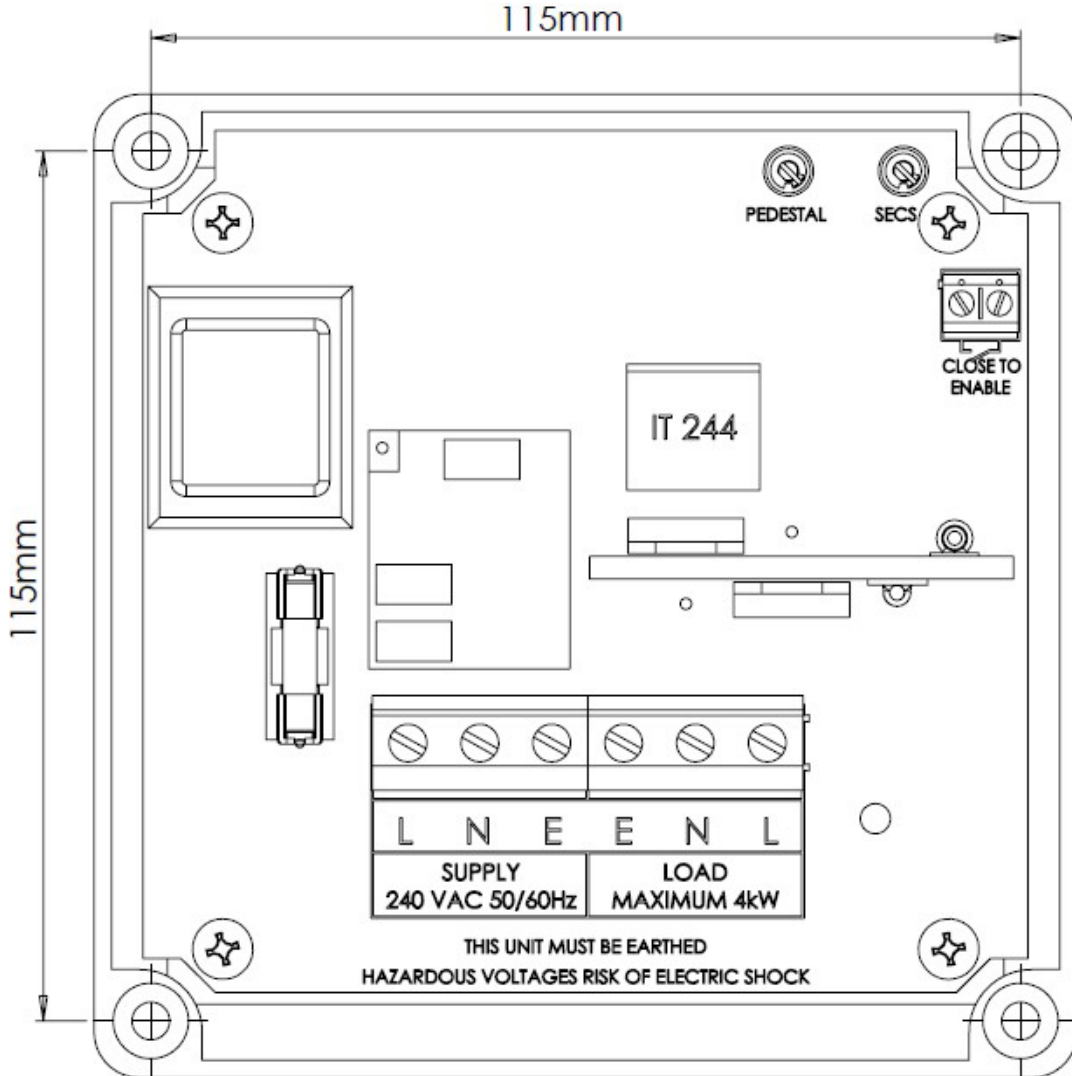

# Soft Start Controller with Bypass Contactor

110v, 230v – 3kW, 6kW Enhance Load Protection and Efficiency

## RECOMMENDATIONS

### FUSING

It is recommended to use semiconductor (fast acting) type fuses or circuit breakers (Semiconductor - MCB) for unit protection. On initial switch on some loads may need an increased Factor of Safety (F of S) for unit and/or device protection. See SRA datasheet for information.

### DOCUMENTS

Other documents available on request, which may be appropriate for your application:

Code	Identity	Description
X10255	SRA	Safety Requirements: Addressing the Low Voltage Directive (LVD) including, Thermal Data/Cooling, Live Parts Warning, Earthing Requirements and Fusing Recommendations
P01.1	COS	UAL Conditions of Sale

It is recommended that installation and maintenance of this equipment should be done with reference to the current edition of the I.E.T. regulations (BS7671) by suitably qualified/trained personnel. The regulations contain important requirements regarding the safety of electrical equipment. For International standards refer STANDARDS on D of C.

## PRODUCT CODE AND RELATED PRODUCT CODE

Product Code	Product Description
A403156	SSC-6kW - 230VAC - Soft Start Controller with Bypass Contactor
A403158	SSC-3kW - 110VAC - Soft Start Controller with Bypass Contactor



BMF House - Wight Moss Way,  
Southport Business Park  
Southport PR8 4HQ  
ENGLAND

