

X10598

HVAC | HEATER BATTERY CONTROLLER

# PR3-E SERIES

12kW, 18kW, 415v

DIN Rail Mounting HVAC Range

Three Phase Burst Fire AC Power Controllers

## CONTACT US:

☎ 0044 (0) 1704-516 501

✉ enquiries@united-automation.com

🌐 www.united-automation.com



## KEY FEATURES:

- ✓ **Seamless Three-Phase Control:** Efficiently manages three-phase electric heating loads.
- ✓ **Zero Voltage Switching:** Minimizes RFI issues for a smoother operation.
- ✓ **Two-Thirds Control Technique:** Available in 12kW and 18kW models for 415V AC supply.
- ✓ **DIN Rail Mounting:** Easy installation on TS35 section DIN rail.
- ✓ **Temperature Trip with Automatic Reset:** Ensures safety with over-temperature protection.
- ✓ **Alarm Output:** Provides 24V AC or DC alarm output, indicating over-temperature or power supply failure.
- ✓ **LED Indicators:** Displays 'OUTPUT-ON' status for easy monitoring.
- ✓ **No Additional Heatsink Required:** Simplifies installation and reduces additional component costs.

## APPLICATIONS:

The **PR3-E Series** is ideal for controlling electric heating coils, heating cables, and electric furnaces. Its robust design ensures reliable performance in various industrial heating applications.

The **PR3-DIN range of thyristor stacks** offers seamless control of three-phase electric heating loads, ideal for integration with a Building Management System (BMS) or similar controllers. These burst firing controllers utilize zero volts switching technology to minimize Radio Frequency Interference (RFI) issues. Available in 12kW and 18kW models, they operate at a typical AC voltage supply of 415V using the two-thirds control technique. Key features include DIN rail mounting capability, DC voltage signal control, automatic reset temperature trip, alarm output, and LED 'OUTPUT-ON' indication. The controllers provide easy access to internal signal and power terminals and do not require additional heatsinks.

The **PR3-E Series** offers a robust and efficient solution for various industrial heating applications, ensuring reliable performance and easy integration.

## TECHNICAL SPECIFICATIONS

Power / Current Ratings	12kW (17A); 18kW (25A) @ 415V RMS
Input Voltage	3 phase from 24V to 440V ac RMS
Frequency	50/60Hz
Input signal (0V-24V)	0 to 10V dc
Power supply (0-24V)	Remote 24V ac or dc +/- 10% @ 40mA (not supplied)
Terminal ratings	(Input signal/alarm/24v supply input) – rising clamp terminal block for 2.5mm <sup>2</sup> cable entry
Alarm output	24V ac or dc (as power supply) normally present. Drops to 0V in the event of over temperature or power supply failure.
Over-temperature	Trip in temperature @ 90°C +/- 5°C, Trip out temperature @ 85°C +/- 5°C
Status Indicator	T1 and T3 indicate output ration
Power Terminations	Rising clamp terminal block for 6mm <sup>2</sup> cable entry
Terminal Torque Settings	0.8Nm (Power Terminals Only)
Fusing	<b>12kW:</b> 20A (20ET) & <b>18kW:</b> 30A (32ET) – both High-Speed Semiconductor type fuses or equivalent MCB's
Max. Ambient Temperature	40°C
Dimensions	<b>12kW</b> 217mm (W) x 87mm (H) x 90mm (including DIN chips) (D) – with firing circuit terminals front facing <b>18kW</b> 217mm (W) x 87mm (H) x 110mm (including DIN chips) (D) – with firing circuit terminals front facing
DIN rail mounting	Using TS35 section DIN rail
Weight	<b>12kW</b> 0.6kg & <b>18kW</b> 0.95kg



BMF House - Wight Moss Way,  
Southport Business Park  
Southport PR8 4HQ  
ENGLAND

united automation

unitedautomationltd UA\_Limited



# PR1-E SERIES

12kW, 18kW, 415v

Three Phase Burst Fire AC Power Controllers

## FUNCTIONS

### Cycle Time and Signal Rescaling

The cycle time is preset for optimal performance. A 0 to 10V DC input signal correlates directly with load output:

- A 5V input signal results in the load being at 50% ON.
- A 2.5V input signal results in the load being at 25% ON.
- A 10V input signal results in the load being at 100% ON.

**CAUTION:** Adjustment of the cycle time and signal rescaling is possible using HD3, HD4, VR1, and VR2, but it is not normally required. Incorrect settings of these controls can cause an overload condition, resulting in failure and permanent damage to the PR3-DIN series. **DO NOT ATTEMPT TO ADJUST THESE CONTROLS WITHOUT CONSULTING THE SUPPLIER OR MANUFACTURER.**

### Manual Override

The PR3-DIN series is preset to the automatic 'A' position. Manual override of the input signal is possible by placing the HD2 jumper plug in the 'M' position. In the 'M' position, the load will be 100% ON. The output load can be adjusted downward using the signal rescaling facility described above.

### Over-Temperature Protection

An electronic thermal cut-out is fitted to the heatsink to protect against over-temperature. The PR3-DIN series will switch off the load if the heatsink temperature exceeds 90°C and will reconnect the load once the temperature drops below 85°C. Under normal operating conditions, the heatsink temperature should not reach 90°C, except in cases where the ambient temperature exceeds 40°C.

### Alarm Output

The alarm output is referenced to 0V and the alarm terminal input. The alarm is triggered by zero voltage presence (as specified).



united  
automation

BMF House - Wight Moss Way,  
Southport Business Park  
Southport PR8 4HQ  
ENGLAND

[unitedautomationltd](#) UA\_Limited



# PR1-E SERIES

12kW, 18kW, 415v

Three Phase Burst Fire AC Power Controllers

## INSTALLATION

### Cooling Requirements

The PR3-DIN series is designed for a maximum ambient temperature of 40°C. Environmental conditions should be assessed, and adequate ventilation, including cooling fans, should be provided in enclosures with limited air changes.

### Location:

The units are designed to be mounted on a TS35 section DIN rail and should be installed with their heatsink cooling fins in a vertical orientation. Ensure sufficient surrounding air space (typically a minimum of 100mm in a vertical plane) to maximize natural convection cooling.

### Load Supply and Backup Protection Considerations

The PR3 series of power controllers are designed for resistive type loads in 'Floating-Star' or 'Closed-Delta' configurations. It is recommended to install a load disconnection switch and contactor in the load supply. The supply to the contactor coil should be interrupted by sensors for over-temperature in the heater and upon airflow loss.

### Control Supply

The control circuitry is fully isolated from the load supply and requires its own 24V (AC or DC) supply. The control supply common is linked to the 0 to 10V input signal common. Ensure all low voltage signal and supply cables are kept separate from high voltage or mains cables, using separate trays or conduit. Screened cables should be used for connections to BMS controllers, with the cable screen connected to a functional earth (NOT mains safety earth). The screen should typically be earthed at one end only to avoid earth loops.

The unit features simple clamp-type connectors for all auxiliary wiring requirements. Refer to the wiring details inside the lid.

#### Note: SAFETY WARNING

- **Isolate the power supply before removing the cover.**
- **Metal parts, especially the heatsink, can become extremely hot during operation.**
- **DO NOT COVER the enclosure ventilation slots.**

It is crucial to install a load break switch and a contact breaker in the load supply. The power supply to the contactor coil should be interrupted by an over-temperature thermostat located in the heater battery and upon detection of airflow loss.



BMF House - Wight Moss Way,  
Southport Business Park  
Southport PR8 4HQ  
ENGLAND

united automation

[unitedautomationltd](#) UA\_Limited



# PR1-E SERIES

12kW, 18kW, 415v

Three Phase Burst Fire AC Power Controllers

## CONNECTIONS

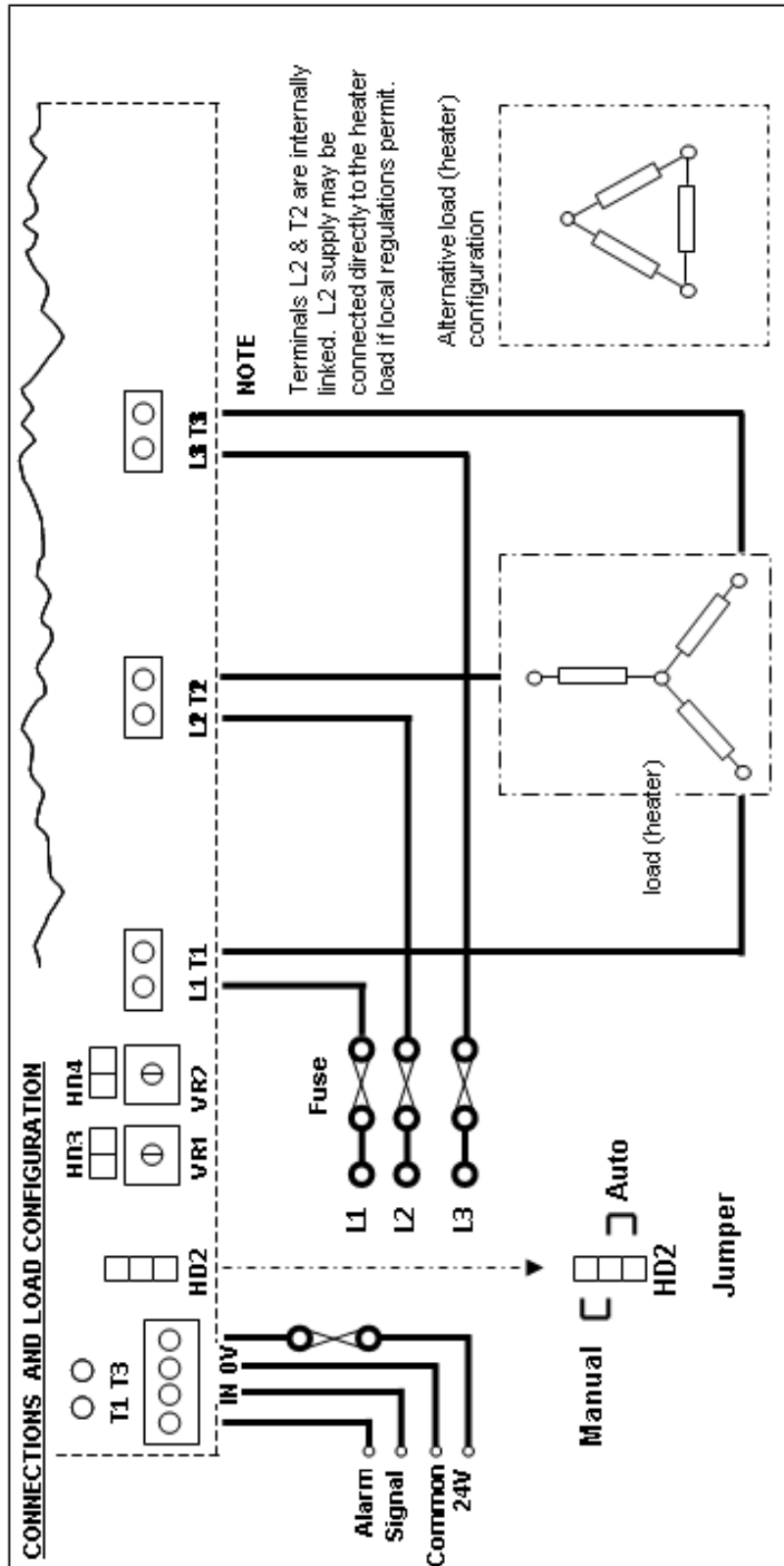

BMF House - Wight Moss Way,  
Southport Business Park  
Southport PR8 4HQ  
ENGLAND



# PR1-E SERIES

12kW, 18kW, 415v

Three Phase Burst Fire AC Power Controllers

## RECOMMENDATIONS

### FUSING

It is recommended that fast acting semiconductor type fuses (as specifications) be used in line with the supply (L1, L2, L3) for protection of the devices. The 24V remote supply should be fused accordingly (e.g. F500mA). See SRA Data sheet X10255 for further information.

### CE Marking

This product family carries a “CE” marking. These burst firing type controllers do not require a filter. For information see recommendations section and contact our sales desk. See the Declaration of Conformity.

## DOCUMENTS

Other documents available on request, which may be appropriate for your application:

Code	Identity	Description
X10213	ITA	Interaction: Uses for phase angle and for burst fire control
X10255	SRA	Safety Requirements: Addressing the Low Voltage Directive (LVD) including, Thermal Data/Cooling, Live Parts Warning, Earthing Requirements and Fusing Recommendations
X10617		Wiring connection details are attached to the inside of the lid
X3-00-001	HVAC	Brochure: Heating Ventilation and Air Conditioning Power Controllers
P01.1	COS	UAL Conditions of Sale

It is recommended that installation and maintenance of this equipment should be done with reference to the current edition of the I.E.T. regulations (BS7671) by suitably qualified/trained personnel. The regulations contain important requirements regarding the safety of electrical equipment. For International standards refer STANDARDS on D of C.

## PRODUCT CODE AND RELATED PRODUCT CODE

Product Code	Product Description
A437317-HV	PR3-E-DIN-12kW, 17A, 415v – Three phase - DIN Mounted
A437318-HV	PR3-E-DIN-18kW, 25A, 415v – Three phase - DIN Mounted



BMF House - Wight Moss Way,  
Southport Business Park  
Southport PR8 4HQ  
ENGLAND

