

X20114

Infrared Heating | Heater Controller



Infresco-P 4kW Controller

4000W, 240v

Energy-Saving Controller with PIR and Temperature Sensor



CONTACT US:

☎ 0044 (0) 1704-516 501

✉ enquiries@united-automation.com

🌐 www.united-automation.com

KEY FEATURES:

- ✓ **Energy Saving:** Activates heat only when people are present, reducing unnecessary energy use.
- ✓ **Extended Lamp Life:** Soft-start and zero-voltage switch-off functions help increase lamp longevity by up to 30%.
- ✓ **Temperature Sensor:** Automatically inhibits lamp operation when ambient temperature exceeds the set point.
- ✓ **Cost-Effective:** Offers advanced features at a competitive price.
- ✓ **Easy Installation:** Simple setup process with minimal maintenance required.
- ✓ **LED Indication:** Blue LED for power ON and red LED for heater ON status.

APPLICATIONS:

The Infresco-P 4kW controller is ideal for a variety of settings, including:

- **Outdoor Heating:** Perfect for patios, terraces, and outdoor dining areas.
- **Commercial Use:** Suitable for restaurants, hospitality areas, and other commercial spaces.
- **Industrial Environments:** Can be used in warehouses, workshops, and other industrial applications where infrared heating is required.

The Infresco-P 4kW Controller is designed to optimize energy usage for Quartz Infrared Halogen Lamps. Featuring a built-in PIR sensor, this model ensures that lamps activate only when people are detected within a 5-meter range and a 100° detection angle. This energy-efficient functionality is further enhanced by a temperature sensor that disables the lamps when ambient temperatures exceed the adjustable set point between 1°C and 60°C.

The microcontroller-based system integrates zero-voltage switching and a soft-start mechanism to mitigate the high inrush current typically seen with lamp activation, potentially increasing lamp life by up to 30%. The lamps remain on for a fixed duration of 5 minutes, which is reset upon detecting further movement. With easy installation and minimal maintenance, the Infresco-P 4kW Controller is a cost-effective and reliable solution for ensuring efficient heating in various applications.

This product is ideal for users seeking a reliable, energy-efficient heating solution with straightforward installation and operation, backed by robust features for enhanced performance and lamp longevity.

TECHNICAL SPECIFICATIONS

Supply Voltage	230VAC ±10% @ 50/60Hz
Switching Capacity	4kW Max.
Detection Range	5 metres
Detection Angle	100°
Temperature Set Point	1 – 60°C
Lamp On-time	5 Minutes (fixed)
Current consumption (control circuit)	50mA
Terminals	2.5mm ² Rising Clamp
Operating Temperature	-20 – 40°C
Protection Rating	IP65
Gland Diameter	Max Cable Entry 2.5mm ²
Enclosure Dimensions (W x L x H)(mm)	100 x 112 x 55



BMF House - Wight Moss Way,
Southport Business Park
Southport PR8 4HQ
ENGLAND

united automation

[@](#) [f](#) [in](#) [d](#) [unitedautomationltd](#) [UA_Limited](#)



Infresco-P 4kW Controller

4000W, 240v

Energy-Saving Controller with PIR and Temperature Sensor

INSTALLATION

Important: Carefully read the following information before installing the unit.

The passive infrared sensor (PIR) in this unit detects changes in infrared energy through the Fresnel lens on its front face. The detection area and range are significantly influenced by its mounting position.

The PIR detects movement of the human body as well as other heat sources similar to it. To prevent false activation, do not position the unit directly facing or in close proximity to the heater lamps. Also, avoid placing the unit near heating flues/exhausts, air conditioning units, moving trees/bushes, and reflective surfaces.

Note: The PIR cannot detect a stationary human body. To ensure the proper function of the PIR sensor, avoid exposing it to rapidly changing temperatures, strong shock or vibration, or high humidity and temperature.



united
automation

BMF House - Wight Moss Way,
Southport Business Park
Southport PR8 4HQ
ENGLAND

[unitedautomationltd](#) UA_Limited



Infresco-P 4kW Controller

4000W, 240v

Energy-Saving Controller with PIR and Temperature Sensor

WIRING DIAGRAM

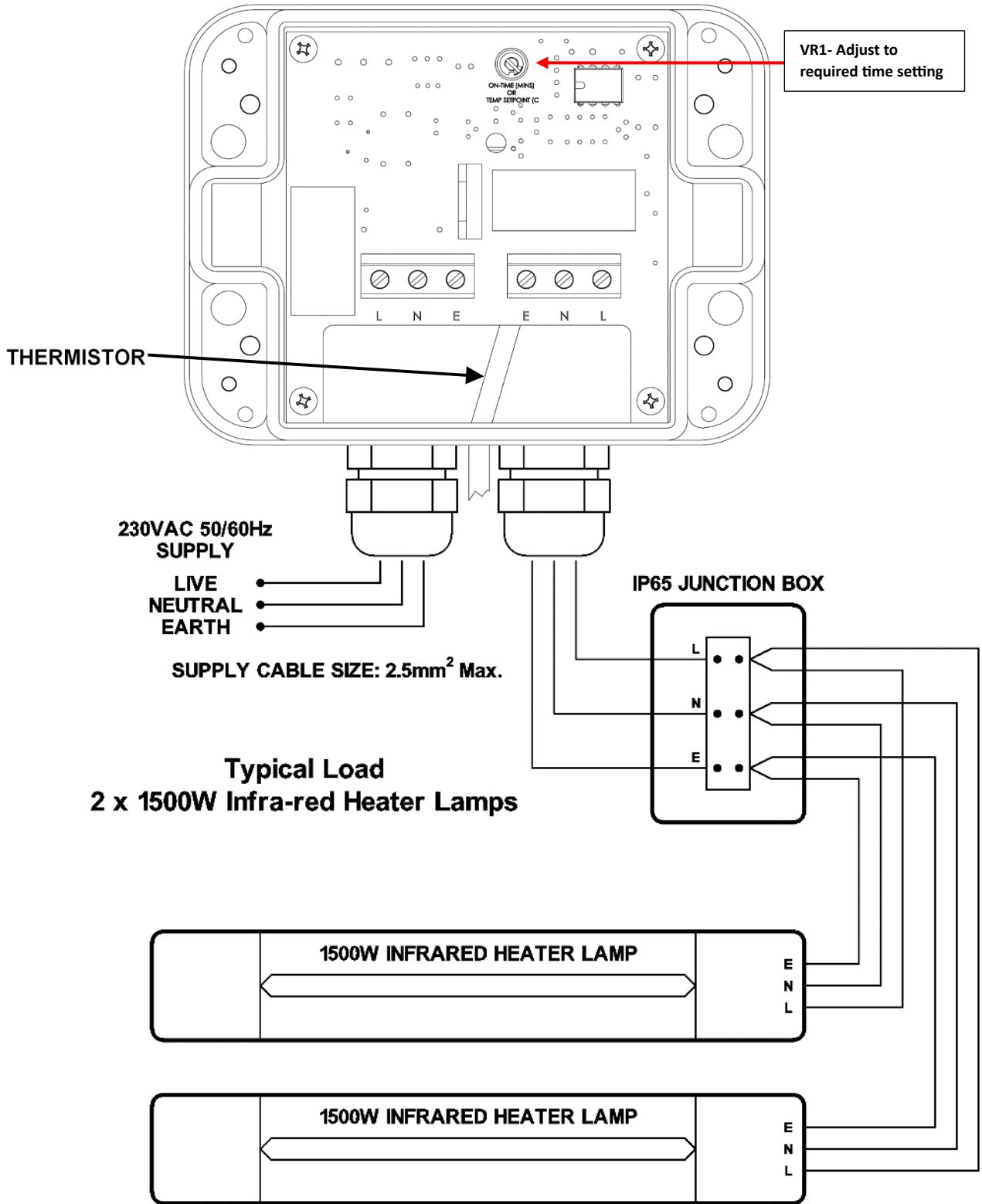

Infresco-P 4kW Controller

4000W, 240v

Energy-Saving Controller with PIR and Temperature Sensor

PIR DETECTION AREA

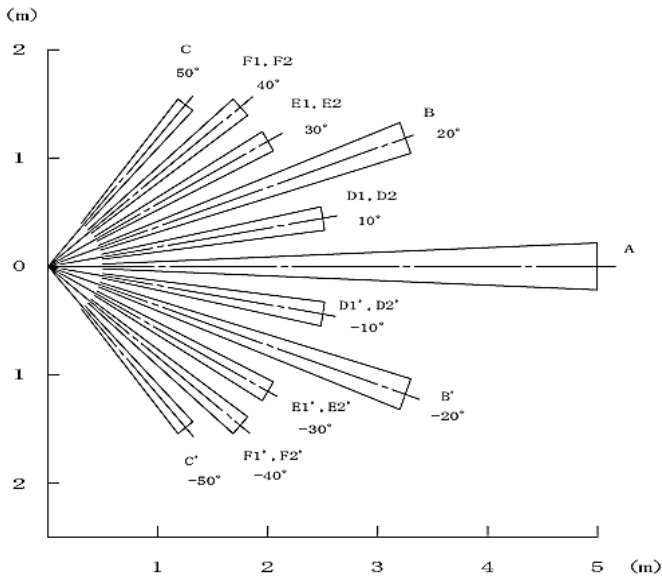

Figure 1: Horizontal Detection

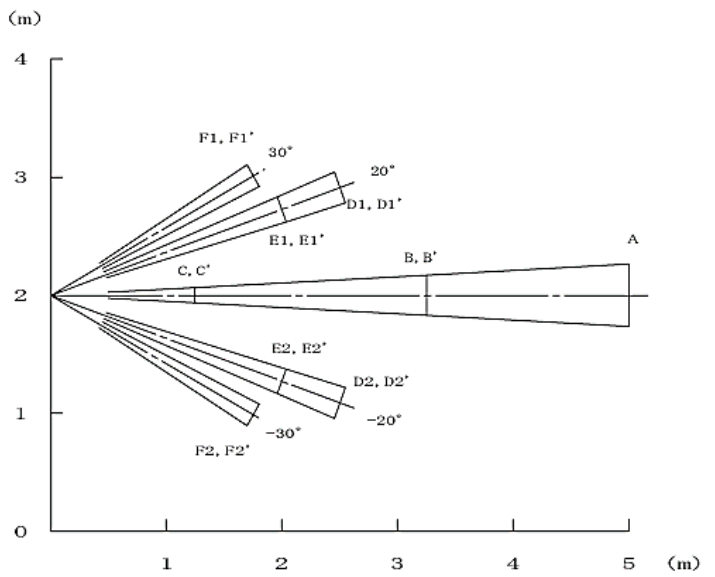

Figure 2: Vertical Detection

POSITIONING

The Infresco-P 4kW can be wall or ceiling-mounted. For wall mounting, the unit should be positioned 1-3 metres high. The diagram above shows the PIR's detection area.

The unit should be fixed securely using the four mounting holes accessible from the front of the unit. Remove the lid to access the mounting holes. To ease installation, a mounting template is provided on the next page to locate the 4 mounting hole centres.

IMPORTANT! When wall mounting, the unit must be orientated with the cable glands facing down.

MOUNTING TEMPLATE

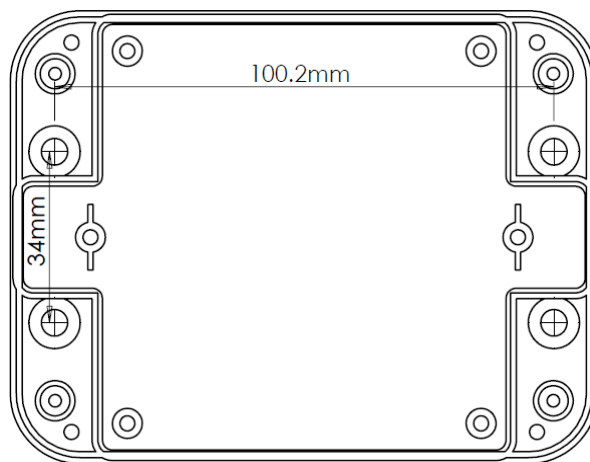

Infresco-P 4kW Controller

4000W, 240v

Energy-Saving Controller with PIR and Temperature Sensor

WIRING

It is recommended that installation and maintenance of this equipment should be done with reference to the current edition of the I.E.E. wiring regulations (BS7671) by suitably qualified/trained personnel. These regulations contain important requirements regarding the safety of electrical equipment (for International Standards refer to I.E.C/ directive IEC950).

Warning! Isolate the mains supply before commencing any work on the unit. Failure to do so could result in serious injury or fatality.

Cable Gland Usage

- The unit is equipped with two cable glands. Ensure only one cable is fitted per gland to maintain the unit's IP rating.
- Refer to the '**Wiring Diagram**' on the next page for an alternative configuration using a junction box.

Mains Supply Connection

- Connect the mains supply to the terminal block marked '**LINE**':
 - Supply **LIVE** to the '**L**' terminal.
 - Supply **NEUTRAL** to the '**N**' terminal.
 - Supply **EARTH** to the '**E**' terminal.

Lamp Connection

- Connect the lamps to the terminal block marked '**LOAD**':
 - Load **LIVE** to the '**L**' terminal.
 - Load **NEUTRAL** to the '**N**' terminal.
 - Load **EARTH** to the '**E**' terminal.
- If connecting two lamps, wire them in parallel.

Warning! Ensure all earth wires are connected to maintain earth continuity to the lamp fittings.

Final Checks

- Verify all wiring connections are secure.
- Ensure the cable glands are tightened properly to maintain the unit's IP rating.

By following these steps carefully, you can ensure the safe and efficient installation of your unit.



BMF House - Wight Moss Way,
Southport Business Park
Southport PR8 4HQ
ENGLAND

united automation

[unitedautomationltd](#) UA_Limited



Infresco-P 4kW Controller

4000W, 240v

Energy-Saving Controller with PIR and Temperature Sensor

COMMISSIONING

Turn the set point temperature pre-set (VR1) fully clockwise to select 'walk test' mode.

VR1 is located at the top of the printed circuit board as shown opposite.

Replace the lid and switch on the mains supply to the unit. The controller will remain idle for 60 seconds to allow the PIR sensor to stabilise.

After 60 seconds, the detection area can be walk tested to verify the PIR's coverage. Each time the PIR detects sufficient movement, the lamps switch on for 5 seconds.

Note: Each time the lamps switch off, the PIR is inhibited for 5 seconds to prevent changes in infrared energy, given off by the lamps, from causing a false activation.

Once the detection area has been verified, adjust the set point temperature as required. This will automatically disable the 'walk test' mode. The lamp on-time is fixed at 5 minutes.

Note: If the ambient temperature exceeds the set point temperature, the lamps are inhibited.

TROUBLESHOOTING

Problem	Solution
Lamps do not switch ON	Check the LINE and LOAD wiring connections to the unit and ensure the mains supply is switched on.
	The ambient temperature may have exceeded the set point temperature. If necessary, increase the set point temperature (VR1).
	Check the lamps/Lamp fittings.
	Contact your supplier.
Lamps do not switch OFF	Ensure nobody enters the detection area for 5 minutes. This will allow the 5 minute on-time to expire.
	The PIR might be continually being re-triggered due to false activations. Mask the PIR lens and wait 5 minutes. If the lamps switch off after 5 minutes, the PIR is receiving false activations. See section 'Installation'.
	Contact your supplier.

RECOMMENDATION & SAFETY REQUIREMENTS

DOCUMENTS

Code	Identity	Description
X10255	SRA	Safety requirements: Addressing the Low Voltage Directive (LVD) including Thermal data/Cooling, Live parts warning, Earthing requirements & Fusing recommendations
P01.1	COS	UAL Conditions of Sale

NOTE: It is recommended that installation and maintenance of this equipment should be carried out by suitably qualified personnel, with reference to the current edition of the I.E.E. Wiring Regulations BS7671. The regulations contain important requirements regarding the safety of electrical equipment.



BMF House - Wight Moss Way,
Southport Business Park
Southport PR8 4HQ
ENGLAND



Infresco-P 4kW Controller

4000W, 240v

Energy-Saving Controller with PIR and Temperature Sensor

ELECTROSTATIC DISCHARGE (ESD)

This product range has been identified as requiring protection from electrostatic discharge (ESD). They include integrated circuits (IC's) that may be damaged or degraded if mishandled. They are much less vulnerable when built in-circuit and suitable and sufficient precautions are taken when being handled.

To address this matter, when the products are sold separately, they are protected in an ANTI-STATIC polyethylene bag.

Appropriate care should be taken when handling the units for installation.

OPTIONAL EXTRAS

Product Code	Product Description
A-HL-E72C-1	Wall Mounted Patio Heater 1.5kW (no remote)

PRODUCT CODE AND RELATED PRODUCT CODE

Product Code	Product Description
A86602	Infresco-P 4kW Energy-Saving Controller with PIR and Temperature Sensor



BMF House - Wight Moss Way,
Southport Business Park
Southport PR8 4HQ
ENGLAND

united automation  unitedautomationltd  UA_Limited

