

X20084

Infrared Heating | Heater Controller



Infresco VR 1.5Kw Control (Fully Variable Version)

1500W, 240v

Optimal Control for Quartz Halogen Infrared Heat Lamps



CONTACT US:

☎ 0044 (0) 1704-516 501

✉ enquiries@united-automation.com

🌐 www.united-automation.com

KEY FEATURES:

- ✓ **Output Control:** Customize your comfort with variable power settings ranging from 30% to 100%.
- ✓ **Simple Wall Mounting:** Easy to install on any wall surface.
- ✓ **IP55 Protection:** Suitable for outdoor installation with dust and water jet protection.
- ✓ **Soft-Start Function:** Gradually switch on the lamp to extend lamp life.
- ✓ **Simple In-Line Wiring:** Connect using 3-core cables for a straightforward setup.
- ✓ **Pre-Selected Heat Output Levels:** Choose from multiple heat settings for optimal comfort.
- ✓ **Power Output Indication:** High-intensity LED shows when power is being regulated.
- ✓ **Integral EMC Filter Suppression:** Reduces electromagnetic interference.
- ✓ **Relay Override at Maximum Output:** Minimizes heat dissipation at full power.

The INFRESCO-VR-1.5KW controller is designed for precise, variable control of mains-driven loads, specifically Quartz Halogen Infrared heat lamps, up to a total of 1.5KW. This advanced microcontroller-based unit features a 'soft-start' function that gradually switches on the lamp, eliminating the initial high inrush current and potentially extending lamp life by up to 30%.

With easy-to-use up and down push-buttons, users can select output levels, indicated by a high-intensity LED that shows when the controller is regulating power to the lamp load. Additionally, a built-in relay override function ensures that at maximum power (100%), the relay bypasses the power devices to minimize heat dissipation, maintaining a lower operating temperature.

The INFRESCO-VR-1.5KW controller is simple to install, low maintenance, and offers robust performance for a variety of settings.

TECHNICAL SPECIFICATIONS

Supply Voltage	230V AC +/-10%
Supply Frequency	50Hz
Load Rating (maximum)	6.5A (1.5kW @ 230V AC & 25°C ambient)
Output Levels	Variable from 30% to 100%
Fusing or MCB Rating (external)	13A (Brown) Mains fuse or 16A domestic MCB
IP Rating	IP55 – Dust protection; protected against water jets
Operating Temperature	-20°C to 50°C
Maximum Ambient Temperature	30°C
Fixings	4 x 3.5Ø holes (on 97 x 82mm centres)
Supply & Load Cable (recommended)	1.0mm ² 400V AC (minimum rating)
Terminal Cable Ratings	2.5mm ²
Terminal Torque Settings (maximum)	0.5 Nm
Weight	500g
Power Consumption (maximum)	70mA
Isolation Voltage	2500V RMS

APPLICATIONS:

- **Patio Areas:** Provides targeted heating for outdoor spaces.
- **Smoking Shelters:** Maintains comfort in smoking areas.
- **Restaurants:** Enhances comfort in outdoor dining.
- **Warehouses:** Keeps large industrial spaces warm.
- **Workshops:** Ensures reliable heating for work environments.
- **Garden Lighting:** Controls lighting to enhance garden aesthetics.



BMF House - Wight Moss Way,
Southport Business Park
Southport PR8 4HQ
ENGLAND

united automation

unitedautomationltd UA_Limited



Infresco VR 1.5Kw Control (Fully Variable Version)

1500W, 240v

Efficient Energy-Saving Solution for Heating and Lighting

INSTALLATION

MECHANICAL FIXING:

Warning: Isolate the mains supply before starting any installation work.

- Remove the four screws securing the front panel of the controller, being careful not to damage the ribbon connector attached to the internal circuit board. The front panel and ribbon connector can be disconnected for wall fixing.
- Mount the controller securely and vertically on a solid wall using suitable wall fixings via the provided mounting holes.

Warning: Do not drill additional holes in the enclosure as this compromises the IP rating and voids the warranty.

- Avoid placing the controller where it may be exposed to water or direct sunlight.
- Maintain an air gap between the wall and the metal heatsink/plate at the rear of the controller for adequate cooling.

FUSING/PROTECTION:

Protect the controller with either a 13A fuse and plug or a suitable remote Fuse/MCB within a distribution panel.

WIRING:

- **DO NOT** use more than one single 3-core cable per cable gland. Use separate cables for the supply connection and the load.
- Loosen the cable glands and feed the cable through, ensuring each gland has the internal sealing grommet fitted to maintain the IP rating.
- Strip back the outer insulation of the 3-core cable to approximately 40mm without damaging the individual cable insulation. Leave the Earth cable at 40mm and cut the remaining two cables back to 30mm. Strip each cable end back about 6mm and feed the whole cable through the correct cable gland.
- Connect the cables to the correct terminals as marked on the printed circuit board, ensuring the Earth wire is at least 10mm longer than the other wires.
- Tighten each cable gland, ensuring the rubber sealing grommet tightly grips the outer insulation of the cables.
- Replace the front cover, ensuring the ribbon connector is securely fitted and the seal is properly seated in the lid's groove.

COMMISSIONING

- Ensure the cover is securely fitted to the unit and the load (lamp) is mounted and connected according to the provided instructions. Switch on the power to the controller.
- The Red 'Status' LED indicator should remain off initially.
- Press the '+' button once to increase the output level to 'Low' and illuminate the Red 'Status' LED. Press the '+' button three more times to reach full power.
- Press the '-' button to decrease the output levels one step at a time. The LED should be illuminated if there is power to the load (lamp).



BMF House - Wight Moss Way,
Southport Business Park
Southport PR8 4HQ
ENGLAND

[unitedautomationltd](#) UA_Limited



Infresco VR 1.5Kw Control (Fully Variable Version)

1500W, 240v

Efficient Energy-Saving Solution for Heating and Lighting

DIMENSIONS & INSTALLATION

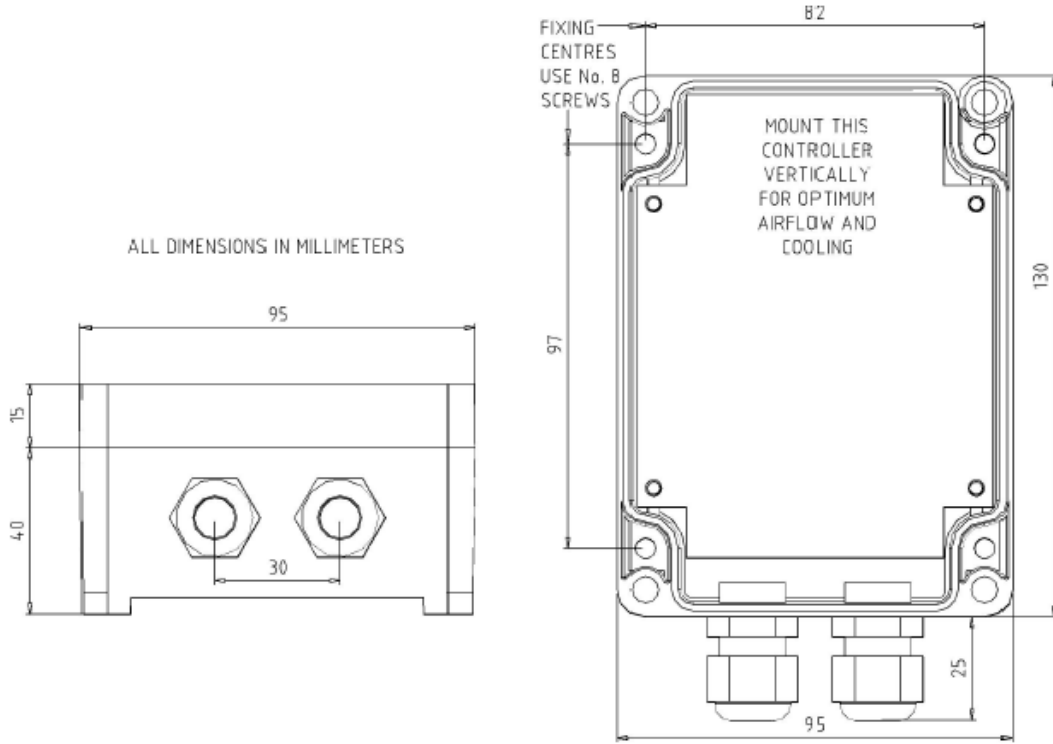

WIRING & CONNECTION DIAGRAM

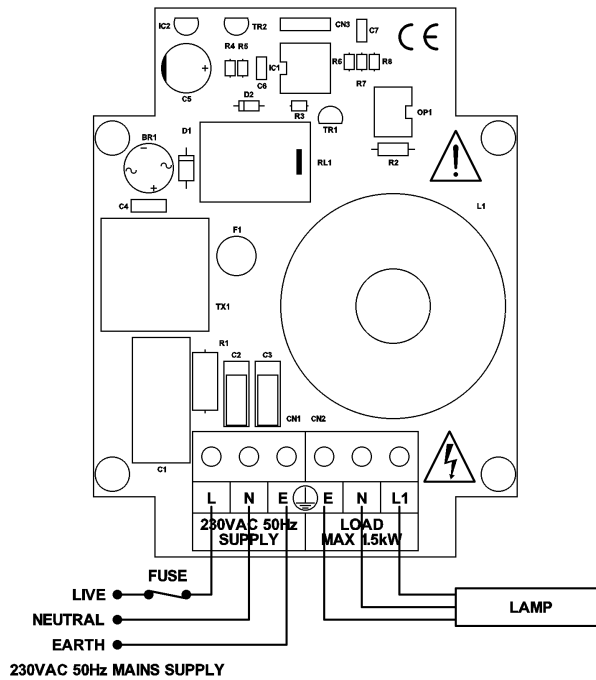

Infresco VR 1.5Kw Control (Fully Variable Version)

1500W, 240v

Efficient Energy-Saving Solution for Heating and Lighting

RECOMMENDATION

SAFETY ADVICE

Warning: This device operates at 'mains potential'. Ensure the power supply is switched off at the source during installation and servicing.

DOCUMENTS

Other documents, which may be appropriate for your applications, are available on request.

Code	Identity	Description
X10255	SRA	Safety requirements: Addressing the Low Voltage Directive (LVD) including Thermal Data/Cooling, Live parts warning, Earthing requirements and fusing recommendations
P01.1	COS	UAL Conditions of Sale

NOTE: It is recommended that installation and maintenance of this equipment should be done with reference to the current edition of the I.E.E. wiring regulations (BS7671) by an approved (NICEIC or equivalent). electrical contractor. These regulations contain important requirements regarding safety of electrical equipment (for International Standards refer to I.E.C/ directive IEC950).

CE MARKING

This unit carries a 'CE' mark and incorporates a filter (complies to BS EN55022 Class B) to comply with the EMC directive. For further details see the Product Declaration of Conformity (DofC).

OPTIONAL EXTRAS

Product Code	Product Description
A-HL-E72C-1	Wall Mounted Patio Heater 1.5kW (no remote)

PRODUCT CODE AND RELATED PRODUCT CODE

Product Code	Product Description
A86711	Infresco VR 1.5Kw Control (Fully Variable Version) - Efficient Energy-Saving Solution for Heating and Lighting



BMF House - Wight Moss Way,
Southport Business Park
Southport PR8 4HQ
ENGLAND

