



Enclosed FAN Controller 15A, 110v & 230v

These variable phase-angle regulators are robust, compact and enclosed units for 230V or 110V up to 15A single phase mains driven inductive loads, such as induction motors, fans and pumps. They give fully adjustable voltage outputs from zero to maximum.

The controller has an integrated RC snubber network for control of inductive loads and a minimum set speed adjuster (at the rear) to allow the designer/installer to fix a minimum output voltage level to prevent a motor being driven too slowly. The large triac enables the unit to handle high inrush currents with ample safety margin on industrial installations. An adhesive backed silver label and hairline knob are included for front panel mounting (or fitted to front of unit).

FEATURES

- Variable 0-98% output.
- Minimum set speed adjuster.
- Single hole fixing.
- Rugged and compact.
- Large TRIAC for inrush protection.
- Integral R-C snubber



APPLICATIONS

Suitable for most

- Simple mains driven motors and
- Fans.

TECHNICAL SPECIFICATIONS

Maximum rms on-state current	15A
Minimum operating current	200mA
Triac limiting rms on state current	25A
Peak one cycle surge @ 10mS	250A
Peak one cycle surge HS model @ 10mS	300A
I ² t for fusing	112 A ² s
Isolation voltage	2500V rms
Maximum recommended unit temperature	70°C
Maximum cable temperature	105°C
Maximum recommended unit load at 20°C ambient, (without extra heatsink)	10A
Maximum recommended unit load at 40°C ambient, (without extra heatsink)	5A
Mains supply +/-10% @ 50/60Hz	110 or 230V ac

UNITED AUTOMATION LTD



Enclosed FAN Controller 15A, 110v & 230v

Connections

CONNECTIONS AND DIMENSIONS

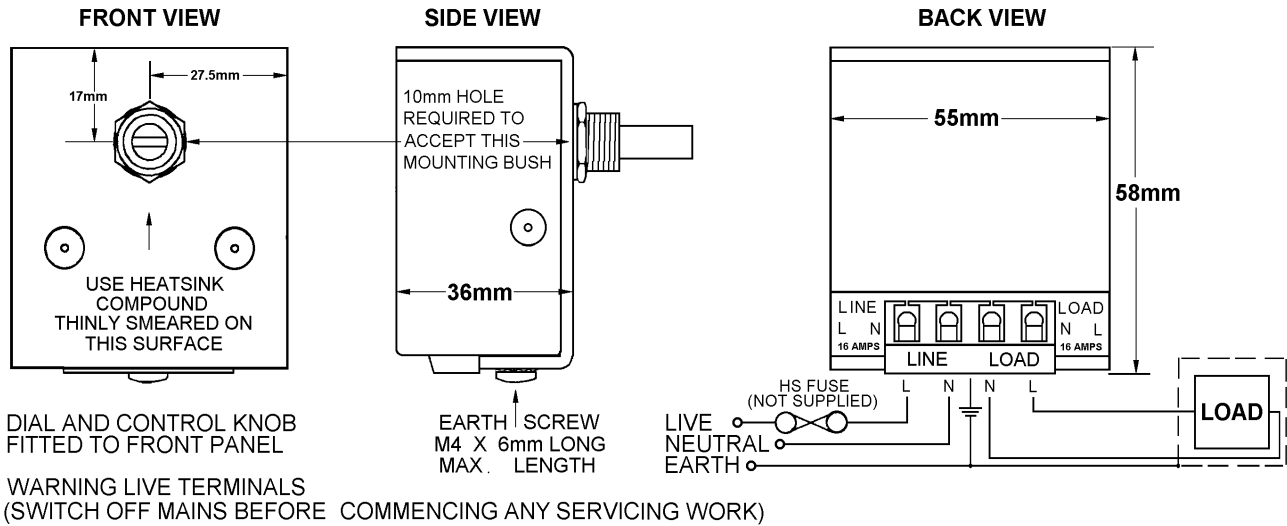

- | | |
|--|--|
| <p>NOTE 1:
 The unit must be fastened to a heatsink (suitable panel) rated at 2°C/W or better for a 15A operation.
 Heatsink paste is essential for use between surfaces (of unit and heatsink) for good thermal bonding.
 See INSTALLATION – cooling requirements.</p> | <p>NOTE 2:
 Minimum set speed adjustment is accessed via a rear cover hole (this is covered by an adhesive label).
 Adjust the cermet screw using a small terminal screwdriver.</p> |
|--|--|

Installation

COOLING REQUIREMENTS

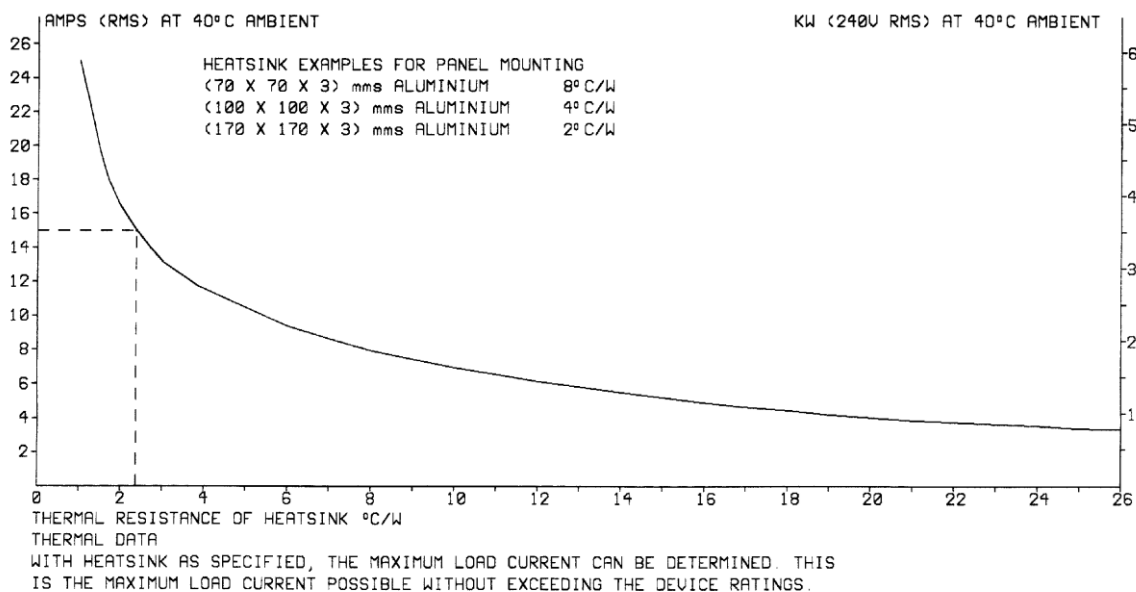

UNITED AUTOMATION LTD



Enclosed FAN Controller 15A, 110v & 230v

Fusing

It is recommended to use semiconductor (fast-acting) type fuses or circuit breakers (Semiconductor - MCB) for unit protection. On initial 'switch on' some loads may need an increased Factor of Safety (F of S) for unit and/or device protection. See the SRA datasheet for further information.

Recommendations

Other documents available on request, which may be appropriate for your application: -

Code	Identity	Description
X10229	RFI	Filter recommendations: Addressing the EMC Directive
X10213	ITA	Interaction: Uses for phase angle and for burst fire control
X10255	SRA	Safety Requirements: Addressing the Low Voltage Directive (LVD) including, Thermal Data/Cooling, Live Parts Warning, Earthing Requirements and Fusing Recommendations

It is recommended that installation and maintenance of this equipment should be done with reference to the current edition of the I.E.T. regulations (BS7671) by suitably qualified/trained personnel. The regulations contain important requirements regarding the safety of electrical equipment. For International standards refer STANDARDS on D of C.

OPTIONAL EXTRAS

Product Code	Product Description
N30001	Control Knob RN-113B SCI
Z01062	Heatsink Compound Syringe (Must be applied while fitting)

PRODUCT CODE AND RELATED PRODUCT CODE

Product Code	Product Description
A72150	15A – 1.6kW 110v fan control enclosed
A72225	15A – 4kW 230v fan control enclosed